

JPC MAGAZINE

www.jpc.rocks

Vol 1 - Issue 12 - August 2024

World Photography Day

Why it Matters

Photo Array

Canon EOS R5 Mark II

First Impressions

Photographers' Profile

Udti Khabrein

**STARTING YOUR
PHOTOGRAPHY
BUSINESS?
WHAT NOT TO DO**

**NURTURING
Your Creative Voice**

Open Talk with Samar S. Jodha

Published by

voilà

voilaindia.com

Scan to visit
our website



 jaipurphotographersclub

 jaipurphotographersclub



awdhesh kumar
HAND BLOCK PRINTS
www.awdheshkumar.in

Available at
www.awdheshkumar.in



Scan for more
Information



President Award in Hand Block Printing

Near Sanganer Flyover, towards Sanganer

✉ info.awdheshkumar@gmail.com

☎ 8769357552, 0141-2790968



Editor's Note

Dear Readers,

It's with immense pride and gratitude that I present to you the 12th issue of JPC Magazine. Reflecting on the past months, it's incredible to see how far we have come. This milestone signifies a year of dedication, creativity, and community that we have built together.

Our heartfelt thanks go to all our contributors who have enriched our pages with their brilliant insights and to our advertisers whose support has been crucial in sustaining our growth. We are also deeply grateful to our subscribers; your continued engagement has inspired us to reach new heights.

I would also like to extend special thanks to our advisors and mentors for their guidance, which has been invaluable at every step. Your wisdom and support have been our compass through this journey.

As we look forward, I am excited about the opportunities and challenges that lie ahead. Together, let's continue to explore, create, and innovate. Your support is our strength, and we are eager to embark on the next chapter with you by our side.

Thank you for being part of our journey.

Anil Khubani
Founder and Editor
JPC Magazine



Purvi Khemani
Assistant Editor

Our Team

Design, Website & Social Media

Voila | Purvi Khemani, Ajay Saini

www.voilaindia.com

Cover Photo by: Rakesh Gogana

Contributors

Samar S. Jodha

Tarkik Verma

Dr. Mohanish Grover

Kuldeep Das

Rakesh Gogana

Website
www.jpc.rocks

Editorial Office
4-Da-5, Jawahar Nagar, Jaipur 302004

Advisors



Dharmendar Kanwar
International Travel Writer
Instagram- deekanwar

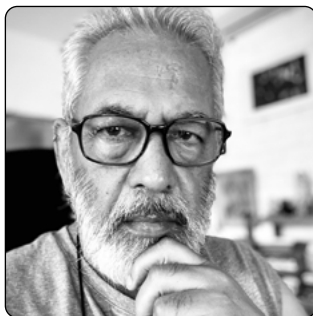

Dinesh Khanna
Freelance Photographer
Instagram- onlydineshkhanna



Vimal Parmar
Independent Marketing
Consultant
Instagram- vimalparmar

JPC Magazine is published & promoted by VOILA, Jaipur

SHYAM DIGITECH

SONY Camera & Lenses Distributor for Rajasthan

No.1
FULL-FRAME
CAMERA BRAND



SONY ZV-E10 Mirrorless Camera Body Only Vlog Camera



α7R_{IV}



α7R_{III}



α7S_{III}



α7_{III}

Contact: +91 98280 24231

Address: Morija Tower, Indira Bazar Rd, Jaipur, Rajasthan 302001



Maximize Your Reach with Targeted Digital Campaigns

Our tailored digital marketing solutions guarantee increased visibility and engagement for your photography business.



+91-9352680033

www.w3care.com

263/845, Pratap Nagar,
Jaipur, India-302033

Contents

- 6 Open Talk with Samar S. Jodha
- 9 JPC Photo Walk Kedarnath Trek
- 10 World Photography Day When & Why It Matters
- 12 Photographers' Profile
- 14 Photo Array
- 18 Starting Your Photography Business: What Not to Do
- 20 Canon EOS R5 Mark II: First Impressions
- 21 First Look at the Godox Lux Master "Potato Masher" Flash: An In-Depth Review



MOTISONS
— JEWELLERS —
JAIPUR



Nurturing Your Creative Voice in a World of Distractions

Open Talk with Samar S. Jodha

Samar S. Jodha, a distinguished artist and publisher whose impactful work spans global organisations like the Bill & Melinda Gates Foundation, BBC World Service Trust, and the United Nations. Notably, over 6 years he documented the iconic Burj Khalifa and Downtown Dubai for the “History in the Making” project, collaborating with esteemed entities such as SOM, Emaar and National Geographic.

Jodha is also recognized for his role as an advisor in corporate social responsibility and has become a prominent speaker at TED and TEDx events. His expertise extends to judging the Nat Geo Cover Shot competition for professional photographers.

www.samarsinghjodha.com

Venue: Arena Animation, C-Scheme, Jaipur
Event Host: Jaipur Photographers’ Club
Moderator: Anil Khubani, Editor, JPC Magazine

On a vibrant day in Jaipur, photographers gathered at the Jaipur Photographers’ Club for a unique opportunity to learn from Samar. The session, titled “Nurturing Your Creative Voice in a World of Distractions,” was held at Arena Animation, C-Scheme, and attracted an audience eager for insights from this seasoned expert.

The talk commenced with a captivating film showcasing Jodha’s diverse journey, allowing the audience to connect with his creative vision. As the film played, it became evident that his dedication to storytelling through art practice is profound, drawing attendees into his inspiring world and enriching their understanding of authentic narrative capture.

The film can be viewed here:
<https://www.youtube.com/watch?v=LFT095IPk-U>

Samar S. Jodha: A Journey of Passion and Purpose

Jodha’s journey into photography embodies a profound passion for storytelling and an unwavering commitment to his craft. After his stint at the National Institute of Design (NID) and further exposure to film, photography and art institutions in the United States, he embarked on a career in vi-

brant advertising photography. Starting as an assistant in automobile and fashion catalogue studios, Jodha gradually distinguished himself in automotive photography. Reflecting on those early experiences, he noted, “The best learning in an advertising photography studio is thinking on your feet; it’s on the cutting edge of commercial photography.”

Despite the allure of financial stability and comfort at this professional start, Jodha felt trepidation about the routine that such success could bring. Every photographer aspires to create a defining book, a mission that ultimately led him back to India. This ambition culminated in the production of half a dozen coffee table books, one of which gained significant recognition, this national award-winning book “Jaipur: The Last Destination’ is in its sixth edition. Largely on art, and architecture design, shot on large and medium film formats to chronicle 900 years of Jaipur’s history. However, the publishing industry’s financial challenges prompted Jodha to pivot towards advertising photography, specialising in diverse realms from automotive to hospitality, from Ms India shoots to collaborating with brands in fashion and beauty.

Transitioning from commercial photography, Jodha felt an underlying fear of becoming trapped in a repetitive cycle. While his goal shifted in his practice, he felt the gloss world had its limitations. The attraction to money and fame could take one to only a certain level in this creative practice. This



that art should extend beyond mere living room walls; it must challenge our consciousness, prompt reflection on our moral compass, and give voice to the voiceless.

<https://www.youtube.com/watch?v=AofFiWS998c>

Open Talk: Insights and Inspirations

The interactive session was expertly moderated by the Editor of JPC Magazine, who posed thought-provoking questions that resonated with photographers striving to find their creative voice amidst the noise of everyday life.

How to Avoid Distractions in the Modern World?

One of the session’s highlights was Jodha’s perspective on overcoming distractions. In an age where technology constantly vies for attention, staying focused can be a challenge.

“If you want to boost your creativity and get into your art seriously, try cutting out distractions, especially from social media. Set some clear goals, find a good spot or targets on research, and long-term projects and limit your time online.

It helps to have a routine, practice being present, do some fun



offline stuff, and set some boundaries.

For Jodha, creativity thrives in silence. “Allow yourself moments of boredom and frustration,” he advised. “These gaps can lead to breakthroughs and push you to explore uncharted territories.”

Improving Compositions: Balancing Technique and Emotion

The conversation then shifted to the art of composition, where Jodha shared insights that blended technical expertise with emotional depth.

“An impressionable photograph is not just about technical perfection; it’s about capturing and sharing your experience,” he emphasised. “While understanding composition rules is essential, breaking them intentionally can create a more compelling story.” He encouraged photographers to experiment and trust their instincts, urging them to create images that resonate with their inner vision. “The camera is just a tool; your storytelling ability is what you bring to the

realisation prompted him to transition from the commercial sphere to work with development agencies and NGOs, including grassroots-level and international bodies.

His attempt has been the artist’ role in sustainability and capacity building, which is beyond picture-making.

<https://www.youtube.com/watch?v=EcqOqeX3Xs8&t=14s>

This also made his shift into documentary projects, notably the eight-year-long portrait endeavour titled “Ageless Mind and Spirit,” which also led him to speak at a TED platform.

TED Talk Link: https://www.ted.com/talks/samar_jodha_listen_to_wisdom_from_the_elders_in_your_life?subtitle=en&geo=hi

Jodha’s focus on public art projects is exemplified by his work on the Bhopal Gas Tragedy, showcasing his innovative storytelling abilities. He created a unique installation, and an experience in a train journey through the darkness on that night. Staged in a 40’ container, it is temperature-controlled to recreate the chill of that night. It’s designed to immerse viewers in the harrowing reality faced by gas leak victims. Inside this enclosure, visitors are enveloped in darkness as images of the Union Carbide Plant are on backlit 3D lenticular images, eliciting a visceral response that mirrors the victims’ despair. This installation, “Bhopal: A Silent Picture,” has travelled across three continents over the past 13 years, attracting more than 350,000 visitors.

“This project was not merely about art; it was about human experience,” Jodha remarked. “The aim is for people to grasp the magnitude of the disaster and its lingering repercussions.” Through his public art initiatives, Jodha illustrates





image, and don't get caught up being a fan of your work. And getting likes on social media is not the approval rating of your ability to make good pictures, or else become an influencer. Remember you are as good as your last photograph, so got to keep moving!" he asserted.

Approaching Clients with Solutions

Navigating client relationships is another aspect that Jodha addressed during the session. He highlighted the importance of understanding the client's needs while infusing one's creative perspective.

"Clients often come with specific expectations, but it's essential to present them with fresh perspectives," Jodha advised. "Be a problem solver and demonstrate how your creativity can add value to their vision." He stressed the importance of not overstepping boundaries, acknowledging that photographers are hired to provide solutions while respecting the client's broader vision.

By offering innovative solutions, photographers can foster partnerships that promote growth and mutual benefits, your long-term goal.

Red Balloon

Jodha is also keenly invested in the youth, a group that he believes has the power to lead and enable social impact. He is the founder of Red Balloon, an organisation that has emanated from his long-held vision of using art to positively set a discourse in society. With this, he has given his vision a platform, creating a collaborative ecosystem, which is critical to large-scale mobilisation and impact. With art and design at its core, team Red Balloon builds partnerships with children of all ages and backgrounds, raises awareness on critical issues and enables individual leadership to lead change.

https://www.youtube.com/watch?v=t_J4cx_Mbrc&t=1s

Samar Jodha's Final Thoughts: Embracing Imperfection and Creativity

As the session concluded, Samar Jodha offered profound insights into the value of imperfection in the creative journey. "Boredom and frustration aren't barriers; they're powerful

catalysts for innovation," he emphasised. "Embrace these feelings, for they can lead you to extraordinary creations." He urged the audience to conquer self-doubt, reminding them that the courage to embrace the risks of success or failure is essential after all, it's not the end of the world"

"Stay away from the comfort zone; it's the end of your creativity. You will fall into the trappings of repeat, predictability, and numbness. Being in the comfort zone of predictability doesn't give you any individuality; it's more like manufactured creativity. And one does wonder about the overall numbness in creativity. It's just that most creative folks like to believe they are on the path of the road less travelled. The real challenge is to self-check between commercial/fame success versus being in an uncomfortable space of fear of failure. After all, hunger is the driving force of any creative individual."

Jodha's words resonated deeply, leaving a lasting impression on the audience and inspiring photographers to cultivate their creative voices amid distractions.

A Token of Gratitude

The event ended on a high note, with a token of gratitude presented to Samar S. Jodha by the Jaipur Photographers' Club. He was gifted a copy of JPC Magazine, a gesture of appreciation for his valuable contributions to the world of photography.

The day concluded with a group shot, capturing the vibrant energy and camaraderie that filled the room. Samar S. Jodha's words of wisdom resonated deeply with the participants, empowering them to embrace their creativity and chart their unique paths in photography.

As the event concluded, the photographers departed with renewed enthusiasm and a deeper understanding of how to nurture their creative voices in a world full of distractions. Samar Jodha's insights reminded everyone that creativity is a journey fueled by curiosity, passion, and the courage to explore the unknown.

Samar Jodha can be found on:

Instagram: <https://www.instagram.com/samarjodha/>

Facebook: <https://www.facebook.com/SamarSJodha>



Kedarnath Temple Trek: An Enchanting Journey Through Aravalli's Monsoon Wilderness

On July 28, an exhilarating trekking adventure unfolded in the heart of the Aravalli hills, as nature enthusiasts gathered for a memorable journey to the Kedarnath Temple. Organised to experience the lush greenery of the jungle during Jaipur's monsoon rains, the trek offered participants a unique blend of adventure, breathtaking landscapes, and camaraderie.

A Diverse Group Embarks on an Adventure

The trek commenced at 6:30AM, with over 20 enthusiastic participants from diverse age groups ranging from 13 to 65+. This remarkable blend of youthful energy and seasoned wisdom set the stage for a memorable expedition. Everyone, from families to solo adventurers, was eager to embrace the challenge of trekking through the hills of the Aravallis.

Conquering the Rocky Terrain

As the group set off, the initial humid weather quickly gave way to a pleasant breeze that accompanied them throughout the day. The rocky terrain of the Aravalli hills presented both challenges and rewards. The trek involved climbing steep



An Enriching Experience

As the trek continued, the group shared stories, laughter, and a deep appreciation for the natural world. The lush green landscapes, vibrant with life, became the perfect backdrop for bonding and reflection. The trek not only tested physical endurance but also nourished the soul, offering moments of tranquility and wonder.

A Day to Remember

The trek to Kedarnath Temple in the Aravalli hills was a resounding success, leaving participants with a profound sense of achievement and a deeper connection to nature. It was a day filled with adventure, exploration, and the joy of being surrounded by the pristine beauty of the monsoon wilderness.

As the trekkers made their way back, they carried with them not only photographs and souvenirs but also memories that would linger long after the trek had ended. The trek was more than a physical journey; it was an exploration of the human spirit, a celebration of nature's grandeur, and a testament to the power of adventure in bringing people together.



Photograph by: Mehul Jain



Photograph by: Mehul Jain

paths, crossing narrow trails, and navigating through dense foliage. The participants displayed incredible teamwork, helping one another as they climbed higher into the hills.

The climb was worth every effort, offering a sense of accomplishment and breathtaking vistas that awaited at every turn. The sheer beauty of the lush green surroundings, glistening under the rain-kissed foliage, made each step a feast for the eyes.

Captivating Views of Jaipur

One of the highlights of the trek was reaching vantage points that provided stunning 360-degree aerial views of Jaipur and its outskirts. The city, draped in a misty embrace, looked like a painting, with its iconic landmarks peeking through the foliage. Photographers in the group seized the opportunity to capture the surreal beauty, creating memories to cherish.

Celebrating World Photography Day

When & Why It Matters

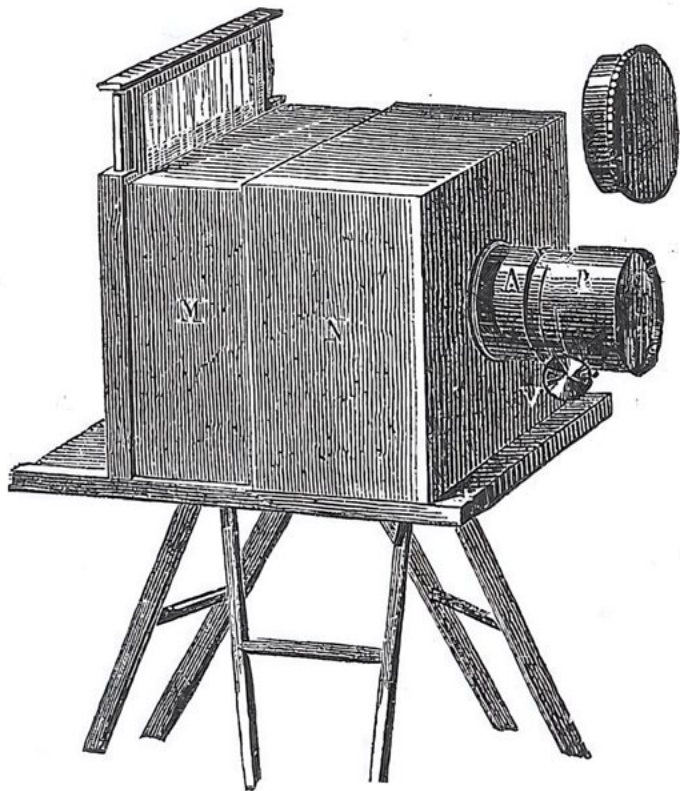

Daguerreotype Camera

Photography is an art form that has captured hearts around the world. Through the lens of a camera, we can capture memories, emotions, and moments that might otherwise fade away with time. World Photography Day is a special occasion that honours this beautiful art. But when is it celebrated, and why does it matter so much? Let's dive into the history and significance of this special day.

When is World Photography Day Celebrated?

World Photography Day is celebrated on August 19th every year. This date is significant because it marks the anniversary of a major event in the history of photography. On August 19th, 1839, the French government announced the invention of the Daguerreotype, the first-ever practical photographic process. This announcement is considered the birth of photography as we know it today. It was the first time that people had a reliable way to capture images of the world around them.

The Birth of Photography

Before the Daguerreotype, attempts to capture images were made, but none were very practical or widely used. The Daguerreotype process, developed by Louis Daguerre in collaboration with Joseph Nicéphore Niépce, was groundbreaking. It allowed images to be captured on a silvered copper plate, creating a permanent and detailed picture.

This invention was a huge step forward and laid the foundation for modern photography. The French government was so proud of this invention that they gave it to the world as a free gift, allowing anyone to use it without paying a fee. This was an extraordinary gesture that helped photography spread across the globe.

Why is World Photography Day Important?

World Photography Day is a time to celebrate photography's impact on our lives. Photography has become a universal language that transcends borders and cultures. Here are a few reasons why this day is so important:

Celebrating Art and Creativity

Photography is not just about taking pictures; it's about seeing the world differently. It encourages people to explore their creativity and express themselves uniquely. World Photography Day celebrates this creativity and the artists who use their cameras to tell stories.

Preserving Memories

Photographs are like time machines. They take us back to



A daguerreotype portrait of Louis Jacques M. A. N. Daguerre by John Jabez Edwin Mayall, a photographic artist who established a studio in London in 1847 and later set up a photographic studio in Brighton, Sussex. This daguerreotype dates from 1846.

Photo Credits: www.lomography.com

moments we cherish, allowing us to relive memories and emotions. Whether it's a family photo from years ago or a recent snapshot from a vacation, photographs hold a special place in our hearts.

Connecting People

In today's digital age, photography connects people like never before. Social media platforms are filled with images that people share with friends and family worldwide. Photography has the power to bring people together, bridging gaps and fostering understanding.

Documenting History

Photography plays a vital role in documenting history. From iconic moments in world history to everyday life in different cultures, photographs capture the essence of humanity. They help us learn about the past and understand the present.

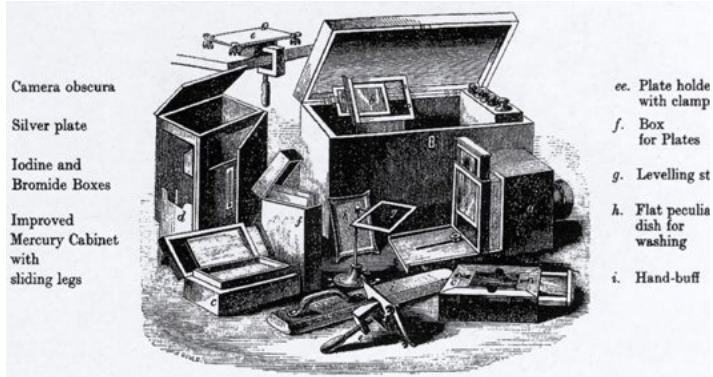

Apparatus and equipment for making daguerreotypes, from an advertisement published in 1843.
Photo Credits: <https://www.photohistory-sussex.co.uk>



A Daguerreotype of Boulevard Du Temple
Photo Credits: www.lomography.com

Raising Awareness

Photographs can also be powerful tools for change. Many photographers use their work to raise awareness about important issues like climate change, poverty, and social justice. A single image can convey a message that words often cannot.

JPC MAGAZINE

Magazine aims to inspire creativity, foster a community of passionate photographers, and promote the art and science of photography.

Special Subscription Offer

12 Print Issues at your Doorsteps
Offer Valid till 31 August 2024

For Just ~~Rs.1500~~ (1350)

Scan to Pay
& Share the screenshot to
+91 94140 75259



Photographers' Profile: Tarkik Verma

Tarkik Verma: Naturalist and Wildlife Photographer

Tarkik Verma is a dedicated naturalist currently working in the field of wildlife conservation and photography. His passion for wildlife photography began in his school days, and over the years, he has seized countless opportunities to work closely with nature.

From a young age, Tarkik was clear about his career aspirations. He always desired to work in harmony with nature, nurturing his love for the environment. The journey from being a mere bird watcher to becoming a professional naturalist was filled with challenges. Yet, it was these experiences, from observing local parks and gardens to exploring the cold deserts of Ladakh, the Thar desert of Rajasthan, the grasslands of Deccan, the renowned Kanha National Park (known for the hard ground Barasingha), and finally the majestic seven hills of Satpura, that instilled in him the values of patience and hard work.

Throughout his career, Tarkik has had the privilege to work on various species, many of which are critically endangered and vulnerable. His expertise in ornithology drew him towards the Great Indian Bustard, his state's emblematic bird. It was the Bombay Natural History Society (BNHS) that offered him the opportunity to study and work with this remarkable species.

Recently, Tarkik achieved a significant milestone when his photographs were featured in Sanctuary Asia's 2024 calendar, including the prestigious cover photo and two additional images. His work has also been published in numerous articles, magazines, and newspapers over the years.

Tarkik's approach to wildlife photography is characterised by his meticulous observation and study of subjects before capturing them through his lens. His dedication to understanding the natural world shines through in his stunning photographs, showcasing the beauty and fragility of wildlife

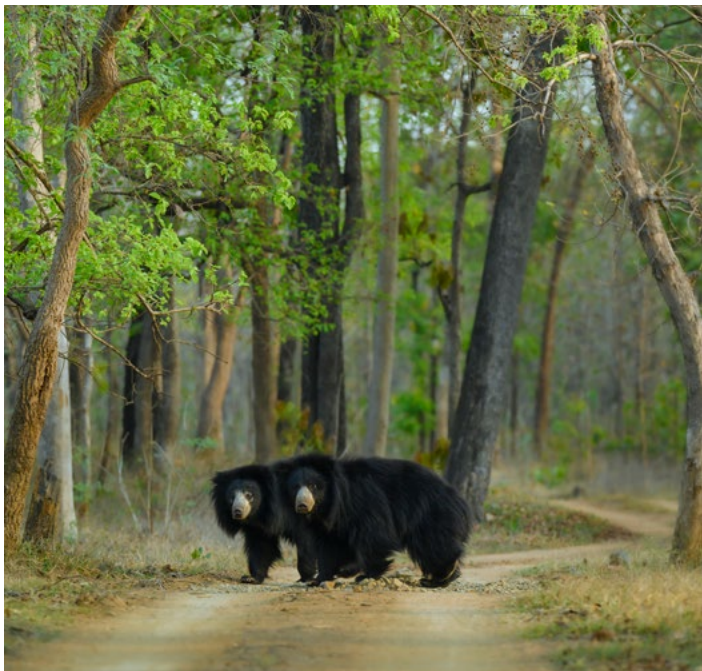



Photo Array



Nikon D500
EXIF - 500mm, f/32, Shutter 1/60, ISO 1280



iPhone
JPC Magazine



iPhone
14

Photo Array



Nikon D500
EXIF - 100mm, f/14, Shutter 1/160, ISO 400



Dr. Mohnish Grover
Jaipur
Instagram: mohnish.grover



Nikon D500
EXIF - 100mm, f/14, Shutter 1/165, ISO 400

Photo Array



Nothing Phone 1



Kuldeep Das
Cuttack
Instagram: kuldeep_kaptures



Nothing Phone 1



Nothing Phone 1



Canon EOS 1500D
EXIF - 18mm, f/11, Shutter 1/30, ISO 1000
JPC Magazine

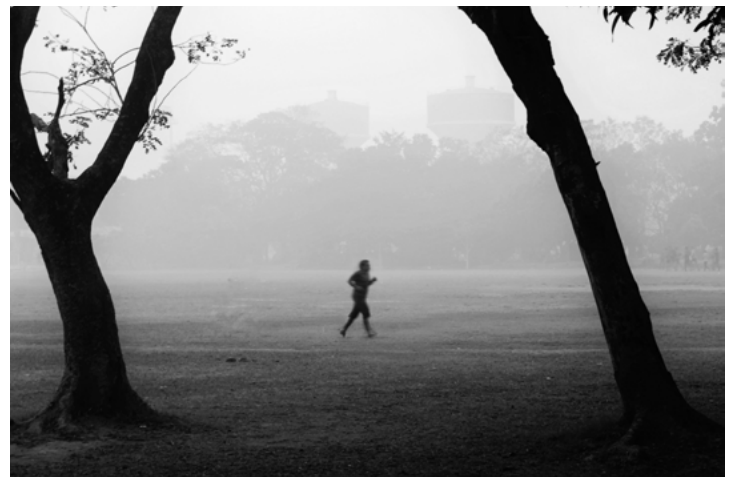

Canon EOS 1500D
EXIF - 47mm, f/10, Shutter 1/25, ISO 100

Photo Array



Canon EOS 6D
EXIF - 105mm, f/6, Shutter 1/20, ISO 400



Sony 6500
EXIF - 18mm, f/8, Shutter 1/125, ISO 250



Sony 6500
EXIF - 18mm, f/9, Shutter 1/80, ISO 500



Sony 6500
EXIF - 18mm, f/8, Shutter 1/100, ISO 200



Rakesh Gogna
Jaipur
Instagram: [explorer_rakeshgogna](https://www.instagram.com/explorer_rakeshgogna)

Apni Toh Paathshala

Starting Your Photography Business: What Not to Do



Top Mistakes New Photographers Make and How to Avoid Them

1. Skipping the Business Plan

A business plan is more than just paperwork; it is your guide to reaching your goals, managing your money, and staying on track. Without one, it is easy to get lost and lose motivation. A good plan outlines who your customers are, what makes you special, how much you will charge, how you will market yourself, and how you will budget. It also helps you monitor your progress and make changes when needed. Keep it simple, clear, and update it regularly.

2. Underpricing Your Services

New photographers often make the mistake of charging too little. This can damage your reputation, lower your income,



and hurt your confidence. It can also lead to demanding clients who expect more than what they paid for or who are unhappy with your work. To set fair prices, research the market, know your costs, and charge based on your skills and experience. Clearly communicate your rates and terms and stick to them.

3. Ignoring Your Online Presence

In today's digital age, having a strong online presence is essential. This is how you show off your portfolio, attract clients, and build your brand. Your online presence includes your website, social media profiles, blog, and reviews. Invest





Don't Ignore Online Presence

time in creating a professional and engaging online presence that showcases your style and personality. Make sure it is easy to find on search engines, works well on mobile devices, and offers a great user experience.

4. Neglecting Legal and Financial Details

Running a photography business is more than just taking photos. You also need to handle legal and financial tasks like contracts, invoices, taxes, insurance, and licences. These might seem dull or overwhelming, but they are crucial for protecting yourself and your clients. Learn what you need to do legally and financially, like registering your business



name, getting a business licence, setting up a bank account, and filing taxes. Use clear contracts and invoices for every job and keep good records of your earnings and expenses.

5. Not Networking or Marketing

Focusing solely on your craft is tempting, but networking and marketing are vital for growing your business. They help you build connections, get referrals, and increase your visibility. Network with other photographers, potential clients, and industry professionals both online and offline. Market yourself through social media, email, word-of-mouth, and

local events. Show off your work, tell your story, and provide value to your audience.



6. Failing to Learn and Improve

Photography is always changing with new trends, technologies, and techniques. To stay competitive, you need to keep learning and improving your skills. Keep up with the latest in your field, try new tools and methods, and seek feedback. Learn from other photographers and find inspiration from various sources. Challenge yourself, set goals, and track your progress.



Uditi Khabre

First Look at the Godox Lux Master 'Potato Masher' Flash: An In-Depth Review

What Comes in the Box

Flash Unit | Sync Cord | USB-C to A Cable | Reflector Dish | Bracket | Carrying Pouch Build Quality

The Godox Lux Master features a robust build, mainly con-



structed from plastic but still feels substantial in hand. The main handle is wrapped in pleather, while the rest is made from chromed plastic, giving it a sleek look. The controls are user-friendly, featuring three buttons, a wheel, and a small OLED touchscreen. It's slightly more intuitive to use than the X3 Nano.

The reflector attaches using a bayonet connection. Although it can be a bit fiddly, it locks securely into place. The bracket

Build Quality

The Godox Lux Master TTL Flash has a robust and substantial feel, despite being made primarily of plastic. The handle is wrapped in pleather, giving it a comfortable grip, while the rest of the body features a chromed plastic finish. The controls are straightforward, consisting of three buttons, a wheel, and a small OLED touchscreen. It's more intuitive to use than the X3 Nano.

The reflector dish connects via a bayonet mount. While the connection can be a bit tricky at first, it attaches securely once in place. The bracket is sturdy, equipped with a lockable

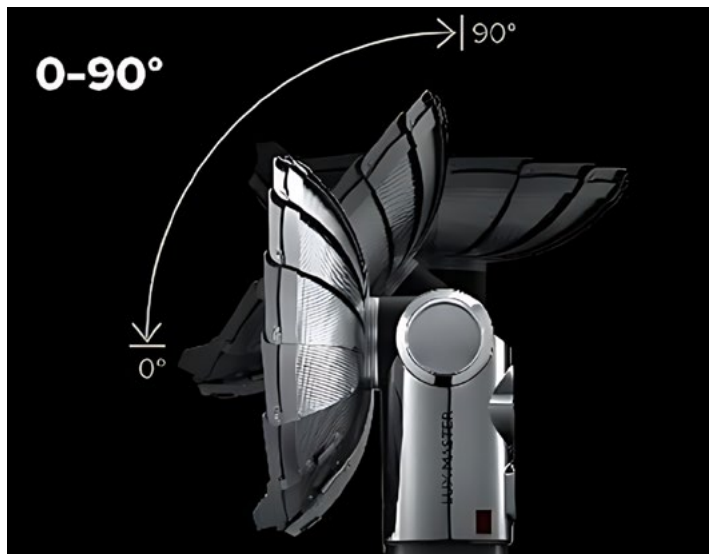

hinge that allows it to be folded away when not in use.

Usage

Like the Lux Senior model, the Lux Master features a retractable flash bulb. A button on the side pops it out when needed. It also includes a small cover for the bulb to protect it when not in use, though this cover is small and could be easily misplaced. The flash head tilts from straightforward to straight up, providing versatile lighting angles.

Setup is straightforward, and the Lux Master connects wirelessly with all X-series triggers tested, including the X1, XPro, XProII, and X3 Nano. Each trigger fired without any issues, allowing full control over the flash settings.

The menu interface suggests that Godox plans to release various modifiers that can attach to the reflector's bayonet connector. The menu allows users to select the specific modifier attached, which presumably adjusts the light intensity based on the modifier used.

Initial test photos taken with the Lux Master show promising results, with good light quality. It's a reliable flash option and will be put to the test in professional settings alongside the V1 flash.





Canon EOS R5 Mark II *First Impressions*

The Canon EOS R5 Mark II has made its much-anticipated debut, and it's already making waves in the photography world. As the successor to the highly praised EOS R5, this new model brings a mix of exciting improvements and innovative features that cater to both professional photographers and enthusiastic hobbyists.

Key Features

One of the standout features of the EOS R5 Mark II is its advanced autofocus system. The camera now boasts 1,053 autofocus points and employs Dual Pixel CMOS AF II technology. This allows for enhanced subject detection and tracking capabilities, making it easier than ever to capture sharp images of moving subjects. Whether you're shooting wildlife or sports, this camera is designed to keep up with the action at an impressive speed of up to 40 frames per second.

Another significant upgrade is the increased image stabilisation. The EOS R5 Mark II offers up to 9 stops of In-Body Image Stabilisation (IBIS), which is a huge benefit for handheld shooting, especially in low-light conditions. This feature ensures that photographers can achieve clear, shake-free images without the need for a tripod, a significant improvement over its predecessor's 8 stops.

In terms of video performance, the EOS R5 Mark II doesn't disappoint. It offers 8K video recording at 60fps, allowing for incredible detail and clarity in every frame. For those who prefer 4K, the camera provides improved frame rates up to 120fps, making it a versatile tool for videographers as well. This model also supports 10-bit 4:2:2 recording, ensuring vibrant and accurate colour reproduction.

Design and Usability

Canon has also made strides in improving the ergonomics of the EOS R5 Mark II. The camera maintains a sturdy yet

lightweight body, weighing just 738 grams with the battery and memory card included. It is comfortable to hold, with intuitive controls that make it easy to navigate through its features. The 3.2-inch vari-angle touch screen offers 2.1 million dots of resolution, providing clear and bright



The new CF-R20-EP fan grip will keep the camera cool when sustained record times are needed.

displays for reviewing shots and adjusting settings. The updated menu system is more user-friendly, ensuring that photographers can quickly access the settings they need.

Connectivity and Battery Life

The EOS R5 Mark II also shines in connectivity options, supporting Wi-Fi 6E and Bluetooth 5.3 for fast file transfers and easy remote control using a smartphone or tablet. Additionally, the battery life has seen an improvement, allowing for up to 870 shots per charge with the LP-E6NH battery, making it more reliable for long shooting sessions.

Overall, the Canon EOS R5 Mark II seems to be a powerful upgrade from its predecessor. With its superior autofocus, improved stabilisation, and impressive video capabilities, it's poised to be a favourite among photographers looking for top-notch performance in a mirrorless camera. Whether you are a professional or just passionate about photography, the EOS R5 Mark II is worth considering for your next camera investment.



Scan the QR code Below
to subscribe the Digital Edition



jpc.rocks



"BANK FD"
I bring
INTEREST INCOME
But,
NO GROWTH on CAPITAL.

**LOOKING FOR
REGULAR INCOME
WITH CAPITAL GROWTH?**



"SWP"

SYSTEMATIC WITHDRAWAL PLAN IN HYBRID MUTUAL FUNDS
I bring
REGULAR INCOME
Rakesh Kumar Jain +
CAPITAL GROWTH
+
EASY ONLINE INVESTING
+
LIQUIDITY.

DISCLAIMER: MUTUAL FUND INVESTMENTS ARE SUBJECT TO MARKET RISK. READ ALL SCHEME RELATED DOCUMENTS CAREFULLY.

Life Insurance | Personal Accident | Health Insurance
Mutual Funds | All Other Insurances & Investment Products

Rakesh Kumar Jain

theфинancedost +91 82094 35281
theфинancedost2023@gmail.com

Check out
our YouTube
Channel



|| सुकृति ||
By R.D

Art | Fashion | Craft
Retail | Customize | Sale

*With an Age Old Legacy of Textile
Trade and the new boost of
Energy into developments,
we are into Trade Forms of
Manufacturing, Trading, Exports
and Agencies.*



@sukritijpr

R.D. Lifestyles, D-89, Janpath,
Shyam Nagar, Jaipur-19
E-manishrdjpr@gmail.com
www.sukritishop.com
M- +91 98290 95493, 98283 84123



SBMFA Financial
Services Pvt. Ltd.

A company registered under Companies Act, 2013

ग्रुप लोन | पर्सनल लोन | एजुकेशन लोन | शॉपकीपर लोन गोल्ड लोन | व्हीकल लोन इन सभी लोन की सुविधा दी जाती है

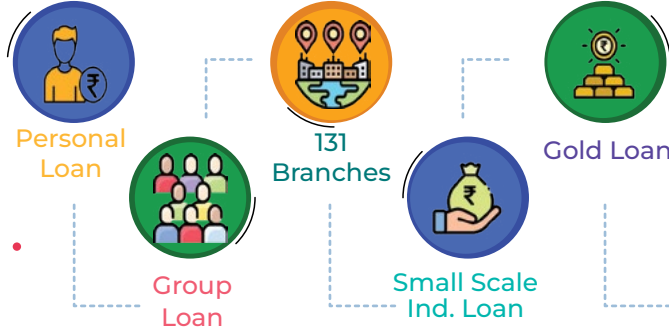

सस्ते और रीजनेबल ब्याज रेट में

114-115, Pushp Enclave, Sector – 5, Pratap Nagar Tonk Road Jaipur – 302033, Rajasthan
Contact : +91 94603 42777 | Email : sbmfa.finserv@gmail.com



Canon
Delighting You Always

CELEBR8
the **MAGICAL**
INDIAN WEDDING
WITH **EOS R8**



The ideal content creation tool for photographers and videographers who need something light, minimalist, powerful yet portable and future-proof.



FLUTED PANELS

Our Range

- SPC Flooring • Stone Vaneers
- Laminate Flooring
- Fluted Panels
- Translucent Stone Veneers

Fluted Panels Specifications

- 12mm Thick • Long Lasting
- Maintenance Free
- Flor Interiors & Exteriors
- Excellent Look and Feel



Classical Surfaces
FUSION WITH NATURE

Contact:- +91 9784243399 +91 9928014491

E-mail:- nakul@earthstoneglobal.co.in

Website:- www.classicals-surfaces.com

Scan for more
Information

